

Manual de Identidade Visual



GRI

*Gerenciamento de
Resíduos Industriais*



Introdução

A imagem de um grupo é formada, além do reconhecimento de seus clientes, da qualidade de seus produtos, serviços e ações comunitárias, pela sua identidade visual : Símbolo, logotipo, tipologia e cores padrão.

Estes elementos combinados entre si de forma própria, exclusiva e coerente nas manifestações visuais emitidas pela empresa, projetam para o mundo exterior e refletem cultura e personalidade.

Este guia estabelece um conjunto de padrões, regras e recomendações que devem ser observados na aplicação da Identidade Visual GRI - Gerenciamento de Resíduos Industriais.

Valorizar o nome GRI e associar à sua identificação atributos como solidez, tecnologia e agilidade, nos levou a realizar este projeto.

Somos todos responsáveis pela formação e manutenção da imagem da empresa, portanto devemos observar estas regras para que haja coerência, unidade e sinergia entre todas as aplicações de nossa Identidade Visual.



Apresentação

A GRI é uma empresa especializada no Gerenciamento de Resíduos Industriais.

Atua em parceria com seus clientes, oferecendo-lhes soluções integradas de gerenciamento de resíduos na planta da indústria, focada nas normas ISO14001/96 e ISO 9001/00. - Operando in site e off site e mobilizando competências de outras empresas do grupo Solví, a GRI executa os serviços de diagnóstico ambiental, inventário e caracterização de resíduos. Também oferece ao cliente, manuseio (incluindo coleta, segregação e acondicionamento), implantação e operação de centros de resíduos, - transporte para tratamento e destinação final, além da implantação e operação de aterros industriais.

A GRI fornece treinamento, auditoria ambiental e planejamento para valorização e minimização da geração de resíduos industriais e eliminação de desperdícios.



Índice

1. Identidade Antiga / Identidade Nova	5
2. Símbolo GRI	6
3. Logotipo Institucional GRI	
<i>Versão Preferencial</i>	7
<i>Versões sem texto e centralizado</i>	8
3.1. Logotipo <i>Variações com endosso Solví</i>	9
4. Cores	10
4.1. Cores <i>Comportamento Cromático</i>	11
4.2. Cores <i>Monocromático</i>	12
5.1. Proteção <i>Área de Proteção</i>	13
5.2. Proteção <i>Redução</i>	14
6. Casos Especiais	15
7. Usos Indevidos	16
8.1. Aplicações <i>Papel de Carta</i>	17
8.2. Aplicações	
<i>Envelope Carta formato 11x23cm</i>	18
<i>Envelope Saco formato 26x36 cm</i>	19
8.3. Aplicações <i>Cartão de Visita</i>	20
8.4. Aplicações <i>brindes</i>	21
8.5. Aplicações <i>lixeiras</i>	22
8.6. Aplicações <i>Camisetas</i>	23
9. Veículos	24



1. Identidade Antiga / Identidade Nova

A identidade visual GRI (símbolo + logotipo) foi redesenhada para, além de atualizar sua imagem perante o público, associar sua marca ao Grupo Solví.

Versão preferencial



GRI

Gerenciamento de
Resíduos Industriais



2. Símbolo GRI

O símbolo GRI obedece a um esquema construtivo preciso para que se mantenha íntegro, sem distorções ou deformações que os diversos processos de reprodução podem provocar.

Para preservar a integridade gráfica do símbolo GRI, não deve ser escaneado de matéria impressa ou redesenhado sem obedecer ao esquema construtivo.

Solicite arquivo digital.

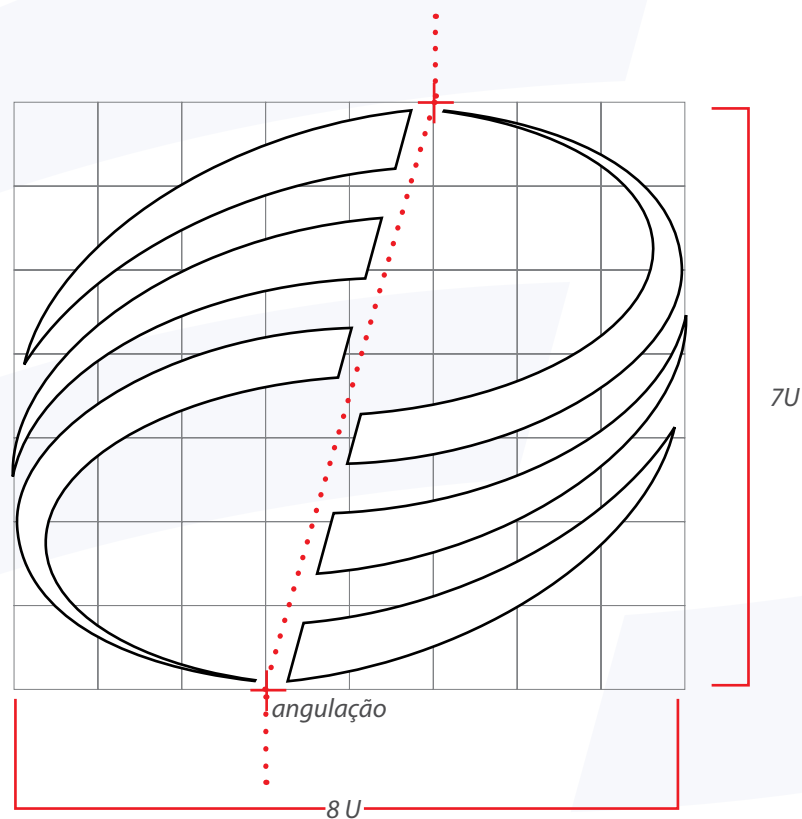

3. Logotipo Institucional GRI - Versão Preferencial

O logotipo GRI foi redesenhado objetivando uma melhor leitura e reprodutibilidade.

Obedece a um esquema construtivo preciso para que se mantenha íntegro, sem distorções ou deformações que os diversos processos de reprodução podem provocar.

O logotipo GRI só pode se associar ao símbolo em 4 formas diferentes e padronizadas:

1. Versão Preferencial Horizontal;
2. Versão Preferencial Centralizada;
3. Versão horizontal sem texto complementar;
4. Versão centralizada sem texto complementar.

Para preservar a integridade gráfica do símbolo GRI, não deve ser escaneado de matéria impresso ou redesenhado sem obedecer ao esquema construtivo.

Solicite arquivo digital.

Versões Preferenciais Horizontal e Centralizada





3. Logotipo Institucional GRI - Versões sem texto e centralizado

Versão horizontal sem texto complementar

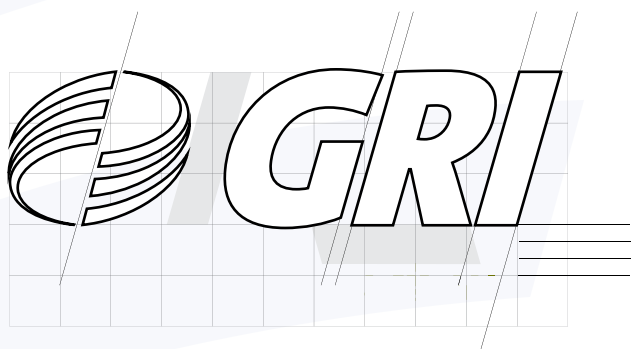

Versão Centralizada sem texto complementar

Uma atenção especial deve ser tomada quanto ao símbolo na aplicação desta versão.

Nesta versão, o símbolo sofre uma ampliação para que sua proporção não fique desvalorizada junto ao logo GRI.

A versão Centralizada só deve ser utilizada quando o espaço disponível não permitir a versão preferencial.

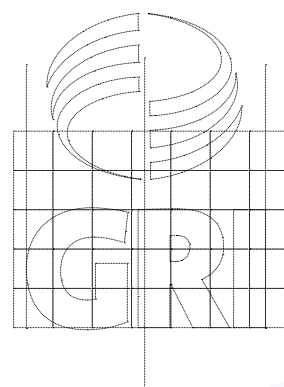

3.1. Logotipo | Variações com endosso Solvi

O uso do endosso Solvi é opcional e só é permitido mediante aprovação da diretoria.

Versões Preferenciais



Versão Horizontal sem texto complementar



Versão Centralizada sem texto complementar



4. Cores

A cor é um principais elementos no processo de memorização da identidade visual de uma empresa e deve ser mantida dentro de um nível de tolerância.

As cores da identidade visual GRI estão estabelecidas neste manual e podem ser obtidas em diversos processos.

As cartelas de cores dos adesivos para aplicação em veículos e equipamentos não têm disponível as mesmas tonalidades das cores GRI.



É necessário criar uma referência própria, que se aproxime ao máximo das cores padrão.



GRI

Gerenciamento de Resíduos Industriais

solví

Pantone	Quadricromia - CMYK	RGB	Adesivo
 <p>Azul Pantone 239 C</p>	<p>Ciano 1000% Magenta 56% Amarelo 0% Preto 0%</p>	<p>R 0 G 82 B 186</p>	<p>3M Scotchcal^{MR} BR 6300 BR 6300 - 67 Azul</p>
 <p>Vermelho Pantone 485 C</p>	<p>Ciano 0% Magenta 100% Amarelo 100% Preto 0%</p>	<p>R 100 G 0 B 0</p>	<p>3M Scotchcal^{MR} BR 6300 BR 6300 - 73 Vermelho Tomate</p>
 <p>Verde Solví Pantone 383 C</p>	<p>Ciano 18% Magenta 0% Amarelo 100% Preto 18%</p>	<p>R 163 G 177 B 7</p>	<p>Imprimax Verde Limão</p>

4.1. Cores | Comportamento Cromático

Usar as cores padrão sobre fundos branco ou cores claras e neutras.





4.2. Cores | Monocromático

Sobre fundo de cores chapadas e imagens complexas, utilizar as versões monocromáticas.

Positivo



Negativo





5.1. Proteção | Área de Proteção

Para que não ocorra interferência na leitura do logotipo GRI, deve-se deixar a área de proteção livre de textos ou elementos gráficos alheios ao mesmo.

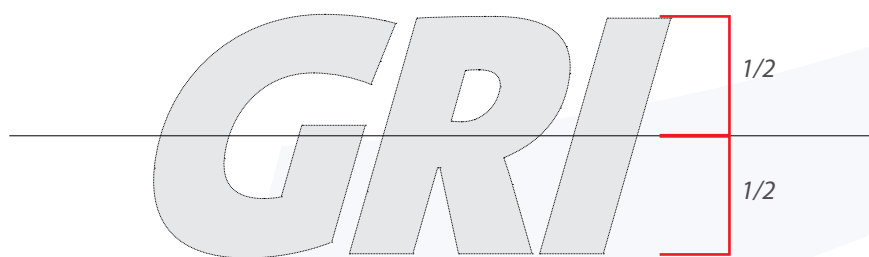



5.2. Proteção | Redução

Para que não ocorra perda de legibilidade e depreciação de qualidade na impressão, não se recomenda utilizar o logo menor que o tamanho indicado.





Em casos especiais somente permitido mediante aprovação da diretoria.

Sobre marcas d'água



Símbolo como marca d'água

Ercil utpat, quis am dip eugiat.

Vullamet, velis erci eum iureet adit ationse velectem et augiam vullandit lutet at veliquip ea consed tet niamcor eratue dolore modit il dolorperatet nonsequat. Xerostrud tin elit essequat in velisl dolore volorper

Sobre fundo preto



Sobre Verde Solví



Recortes nos elementos do símbolos para ilustrar materiais impressos ou de internet

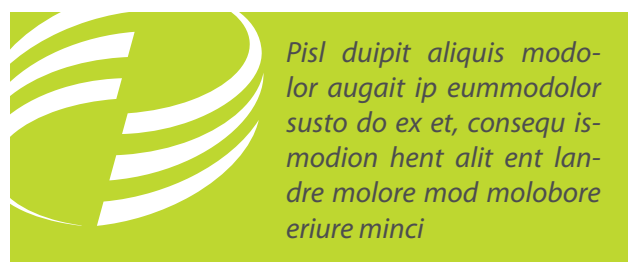

Pisl duipit aliquis modolor augait ip eummodolor susto do ex et, consequis modion hent alit ent landre molore mod molobore eriure minci

Texturas em relevo seco (simulação)



Aplicações em Hotstamping (simulação)

simulação em ouro



Aplicações em Hotstamping (simulação)

simulação em prata



7. Usos Indevidos

Marca posicionada ao lado direito ou deslocamentos fora do padrão



Contorno ou efeitos de sombras em qualquer cor ou espessura



Distorções



Rotacionar



Invasão do campo de proteção



Equis nullaor sisi. Liquisn olortis senisl diamet ad modip ea consensici blaor sum zzrit et lobore faciduis alit wis nulputem exer aut lorem alit er seniam ex ea feu faciliq uissequat.

Cores fora do padrão



Contrastes inadequados



Sobreposição de elementos que compõem o logotipo



Troca tipográfica



Desproporção do símbolo com o logotipo. Desagrupar e ordenar o logotipo em formas que não estão previstas





8.1. Aplicações | Papel de Carta

Tipologia: Myriad pro corpo 9, para o DDD, corpo 7



Praça Alberto Lion, 366
Mooca, São Paulo - SP
CEP 01515-000
Tel.: 11 2165.3666 Fax: 11 2165.3649
gri@solvi.com



8.2. Aplicações | Envelope Carta formato 11x23cm

Tipologia: Myriad pro corpo 10, para o DDD, corpo 8

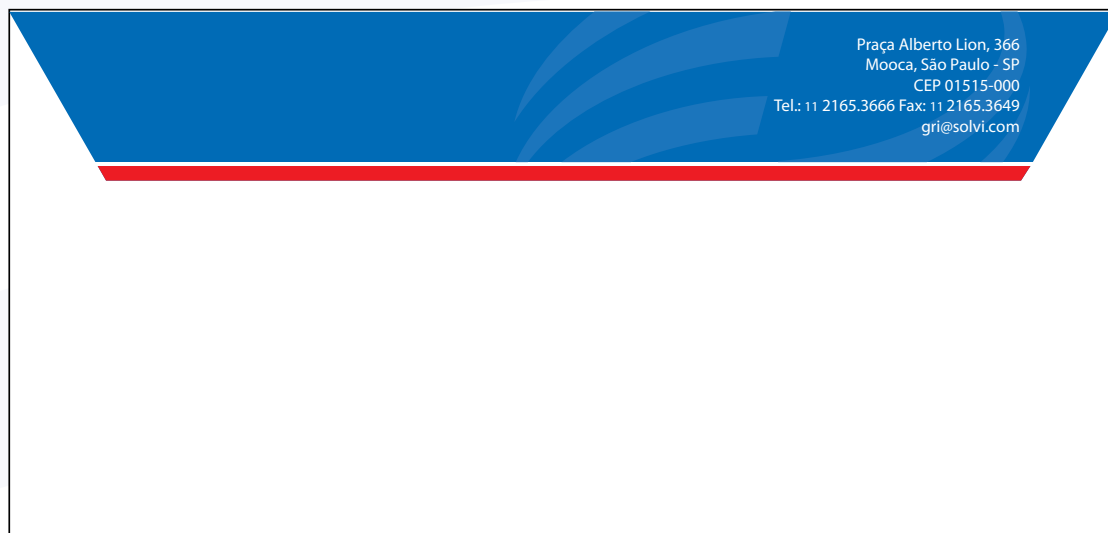



8.2. Aplicações | Envelope Saco formato 26x36 cm

Tipologia: Myriad pro corpo 10, para o DDD, corpo 8





8.3. Aplicações | Cartão de Visita

Nome: myriad 10 bold italic

Cargo: myriad 8 italic

Endereço: myriad 6 regular, DDD





8.4. Aplicações | brindes





8.5. Aplicações | lixeiras





8.6. Aplicações | Camisetas





9. Veículos | Caminhão Toco

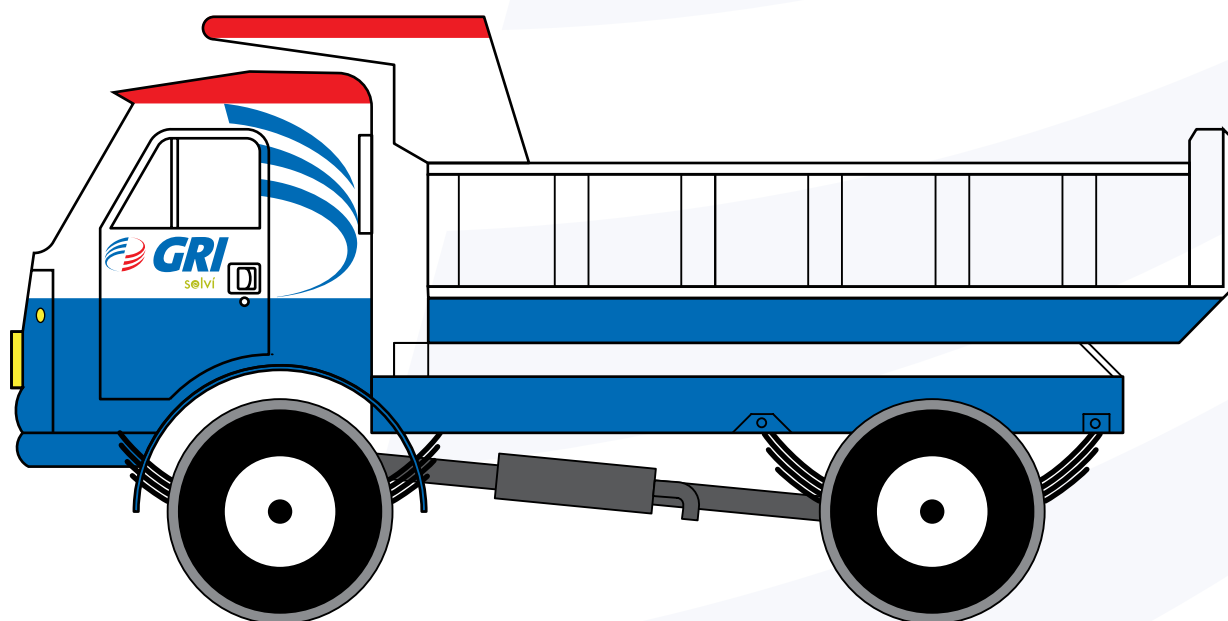
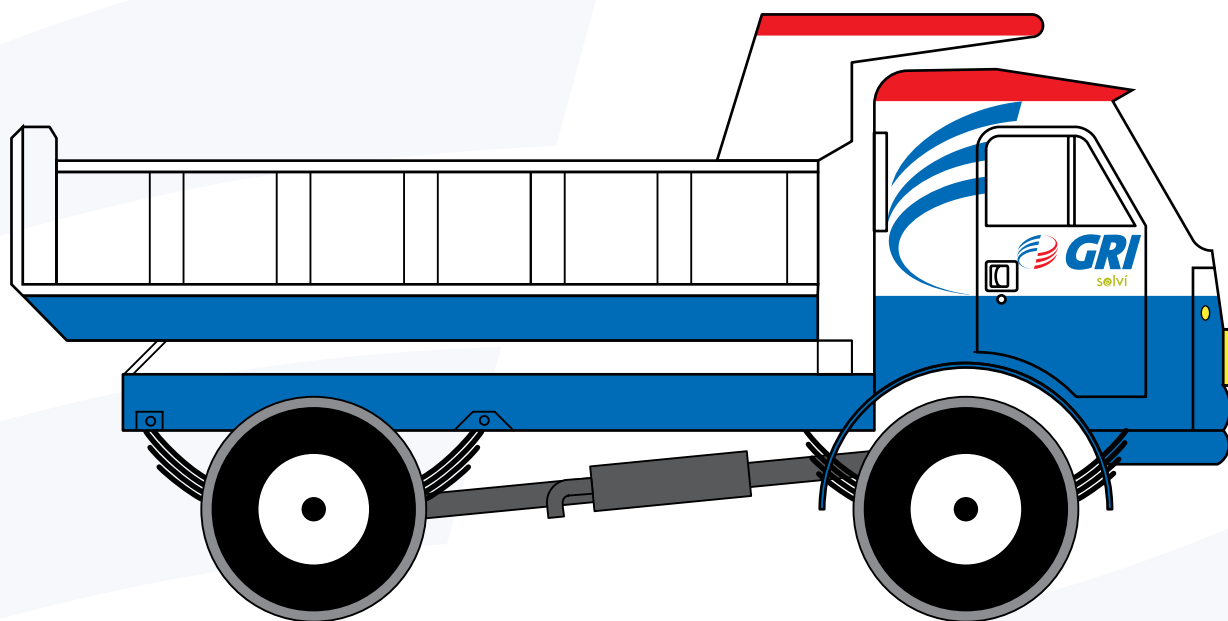



9. Veículos | Caminhão Baú

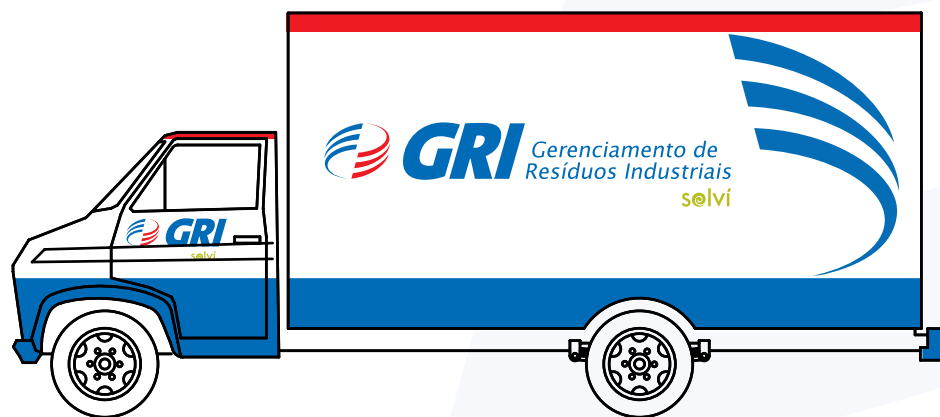



9. Veículos | Caminhão Baú





9. Veículos | Carreta





9. Veículos | Coletor





9. Veículos | Carro Guincho

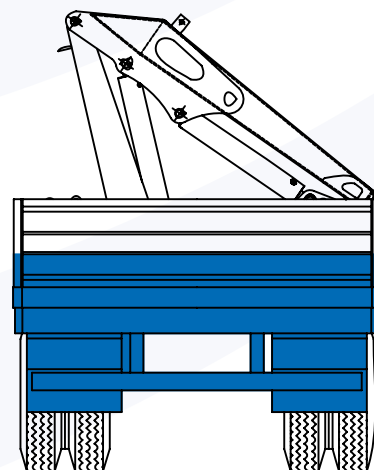
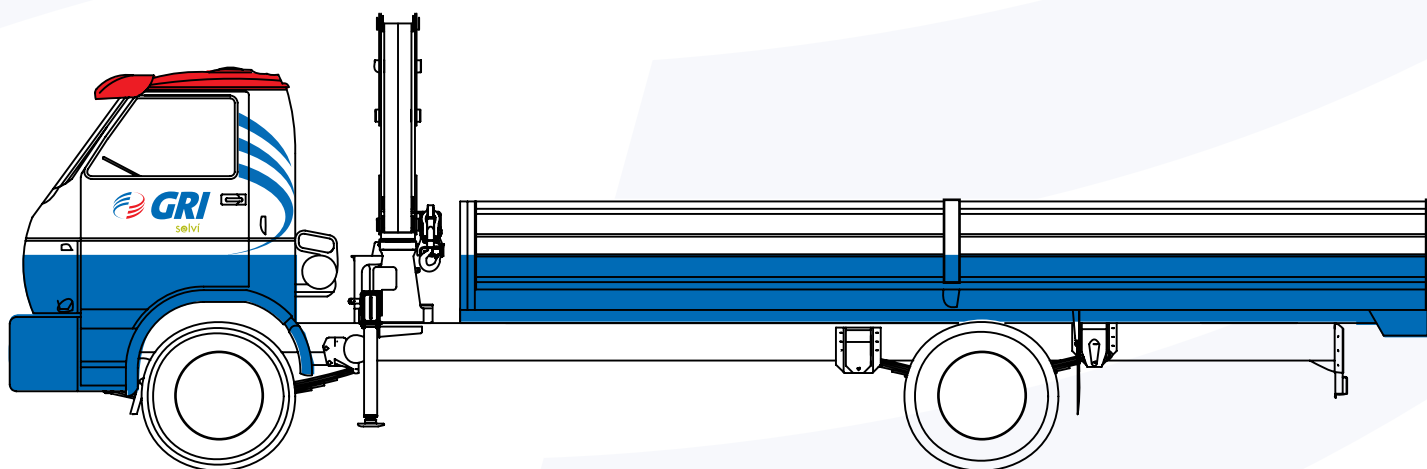
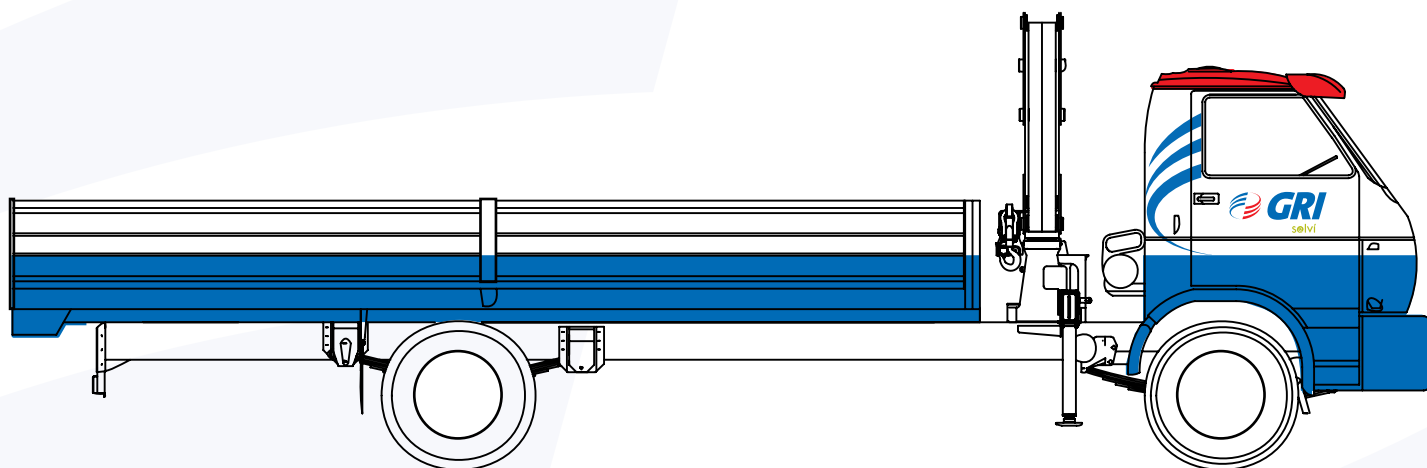



9. Veículos | Caçamba

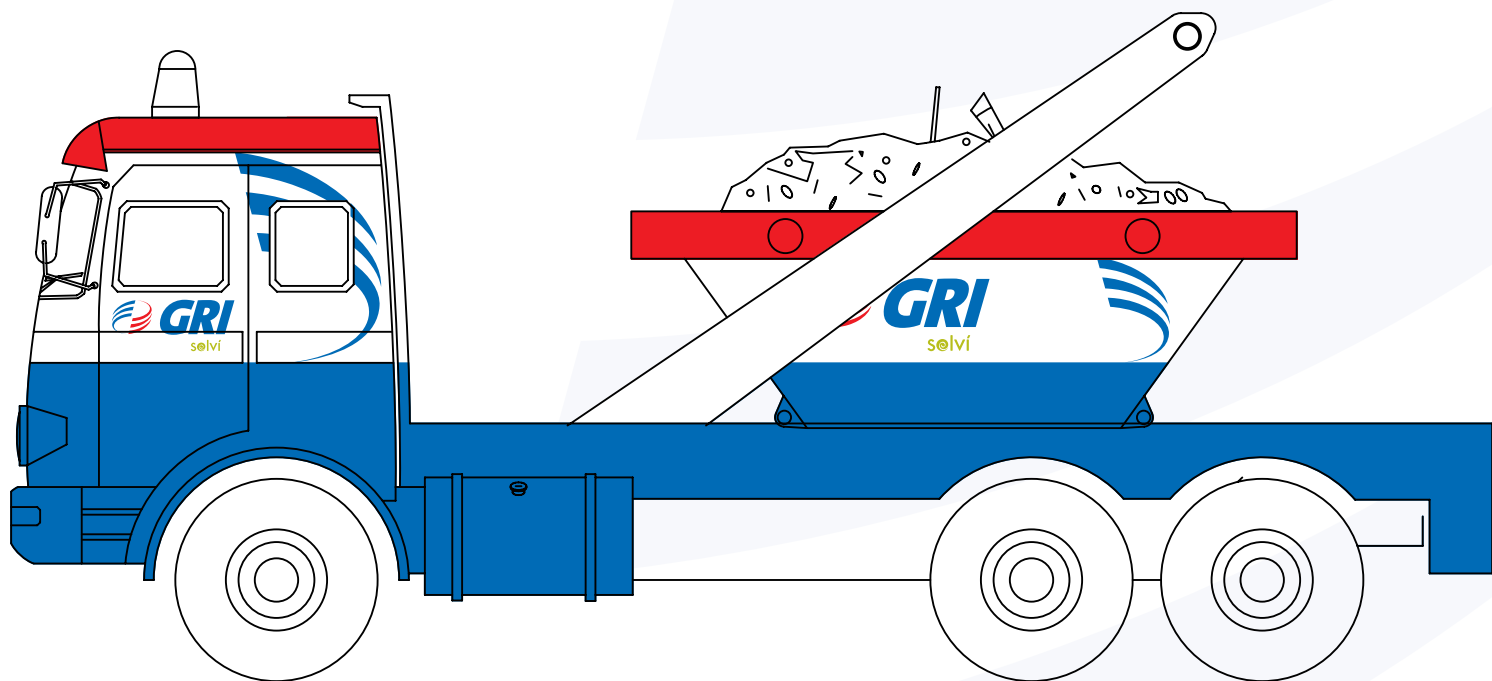
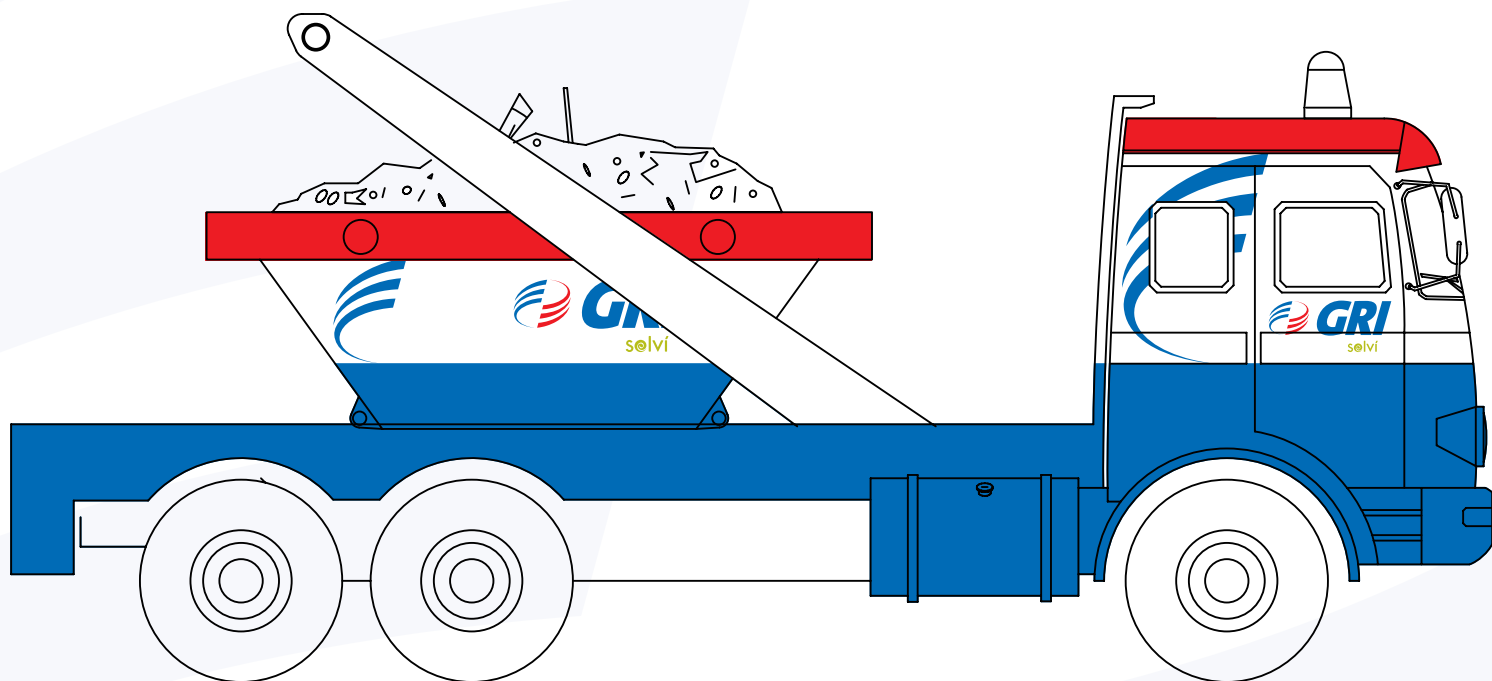



9. Veículos | Sucção à Vácuo

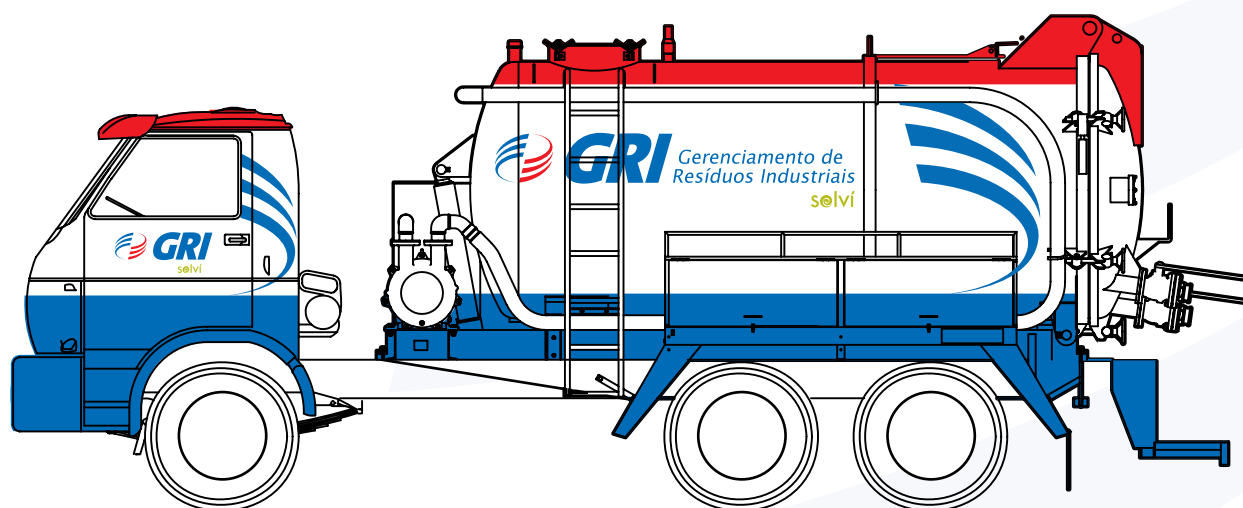
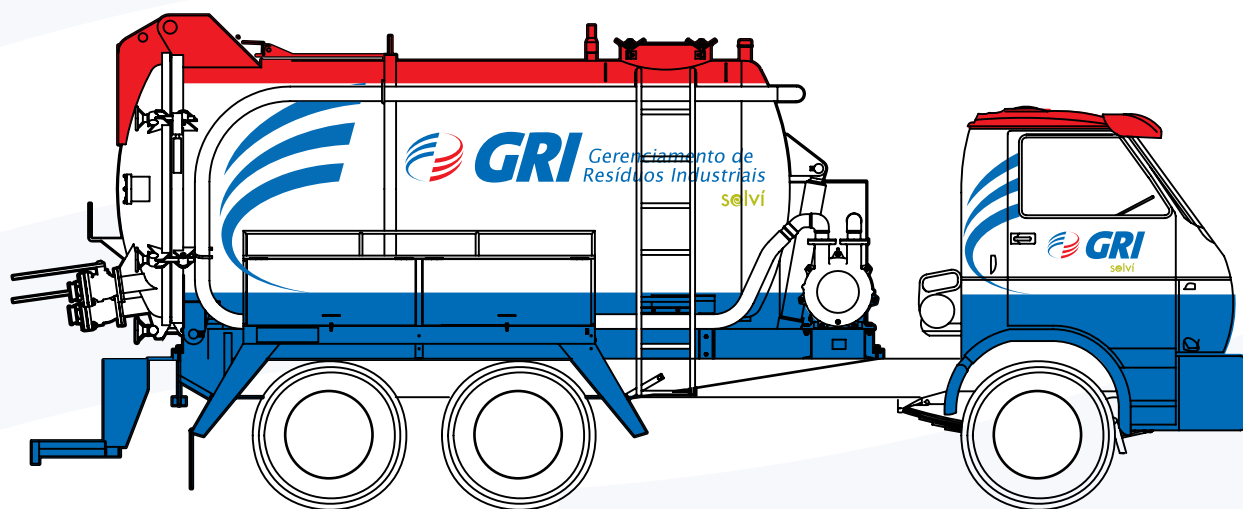



9. Veículos | Ônibus





9. Veículos | Vans

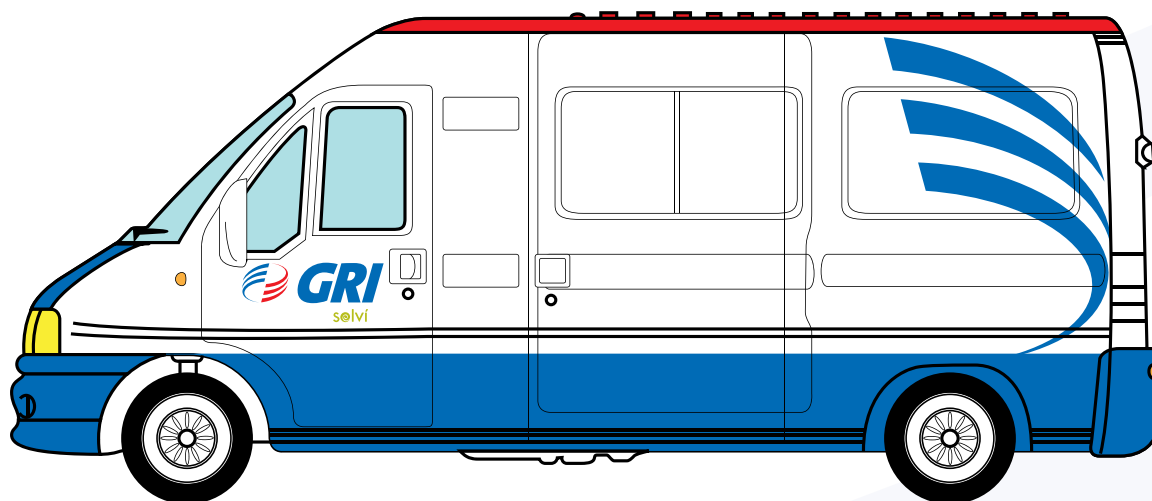
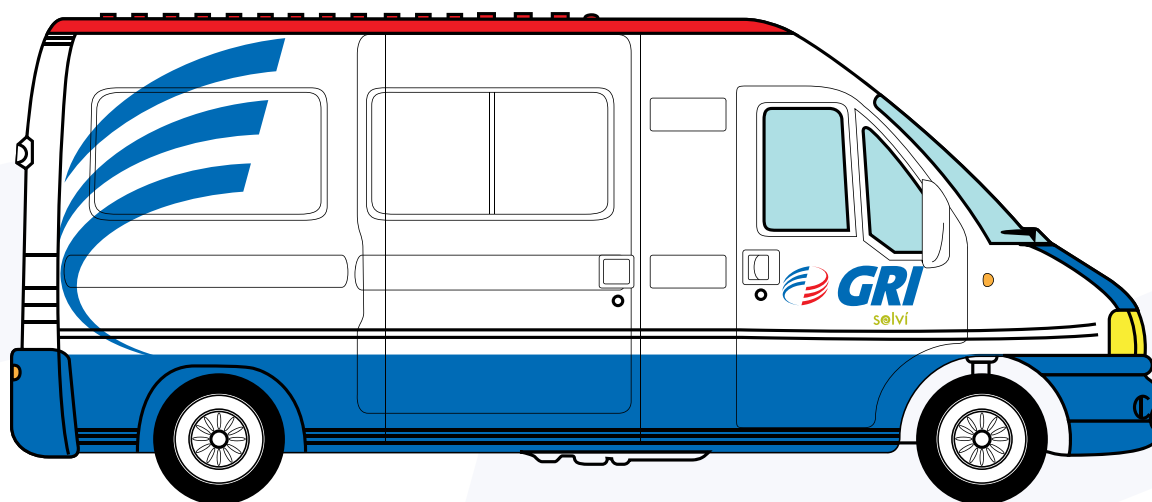



9. Veículos | Kombis

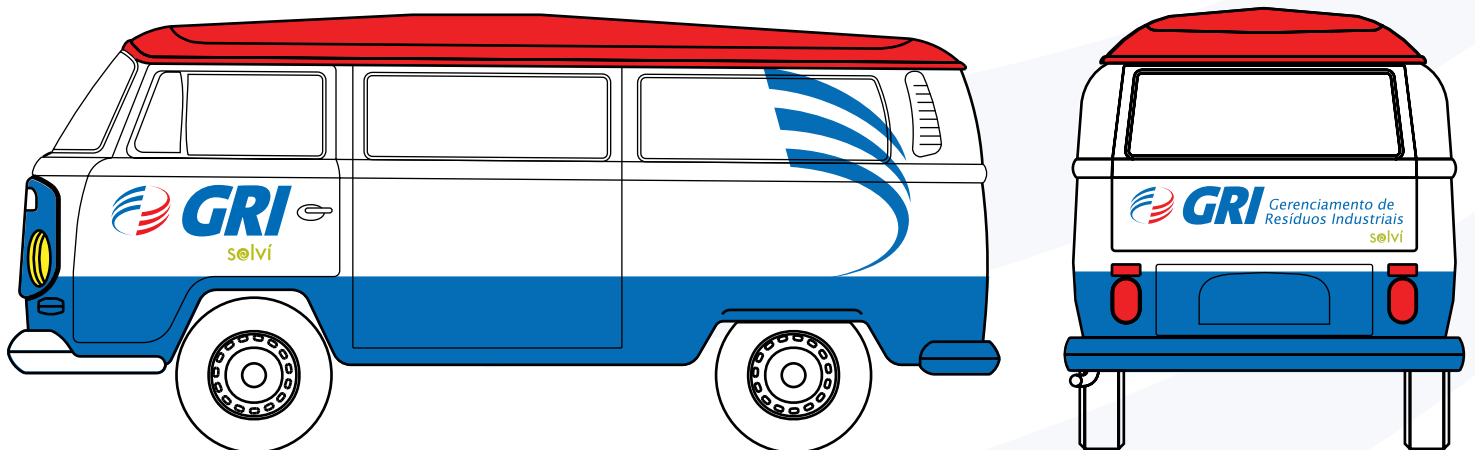
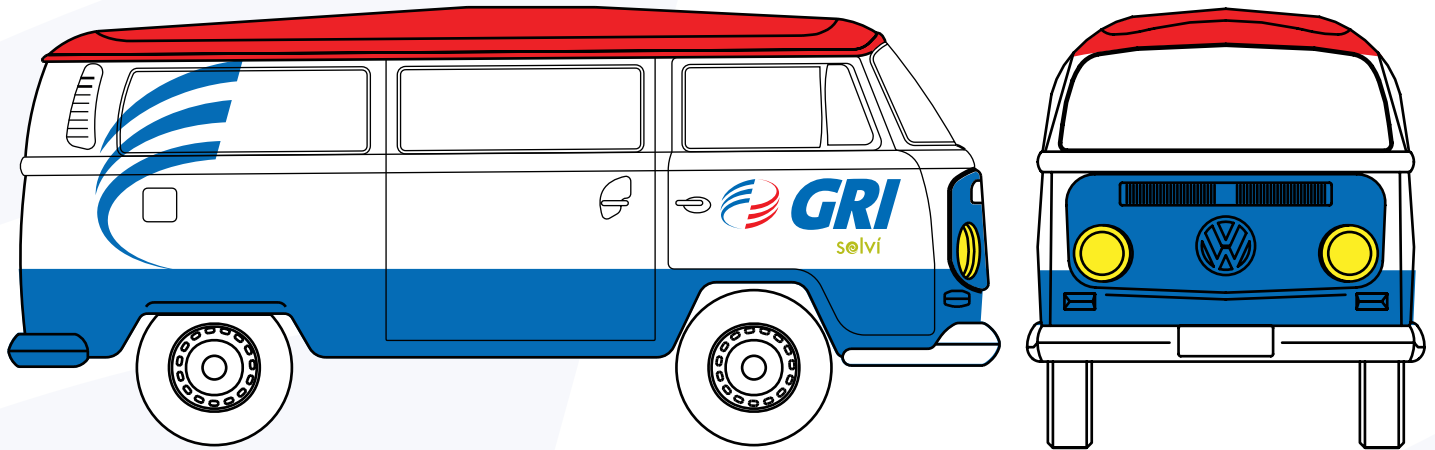



9. Veículos | Bobcat

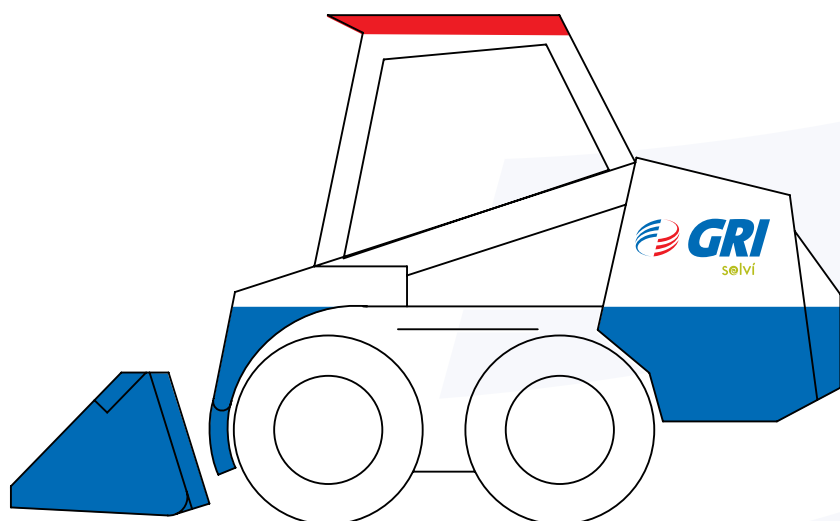
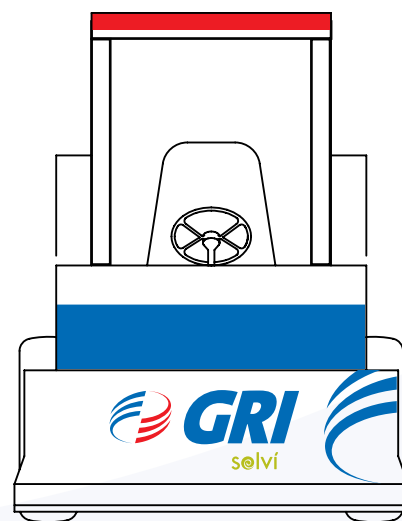
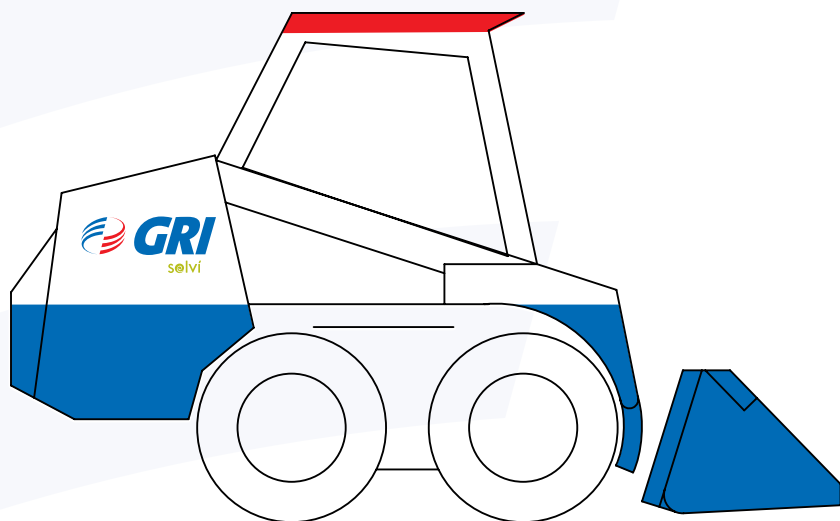



9. Veículos | Retroescavadeira

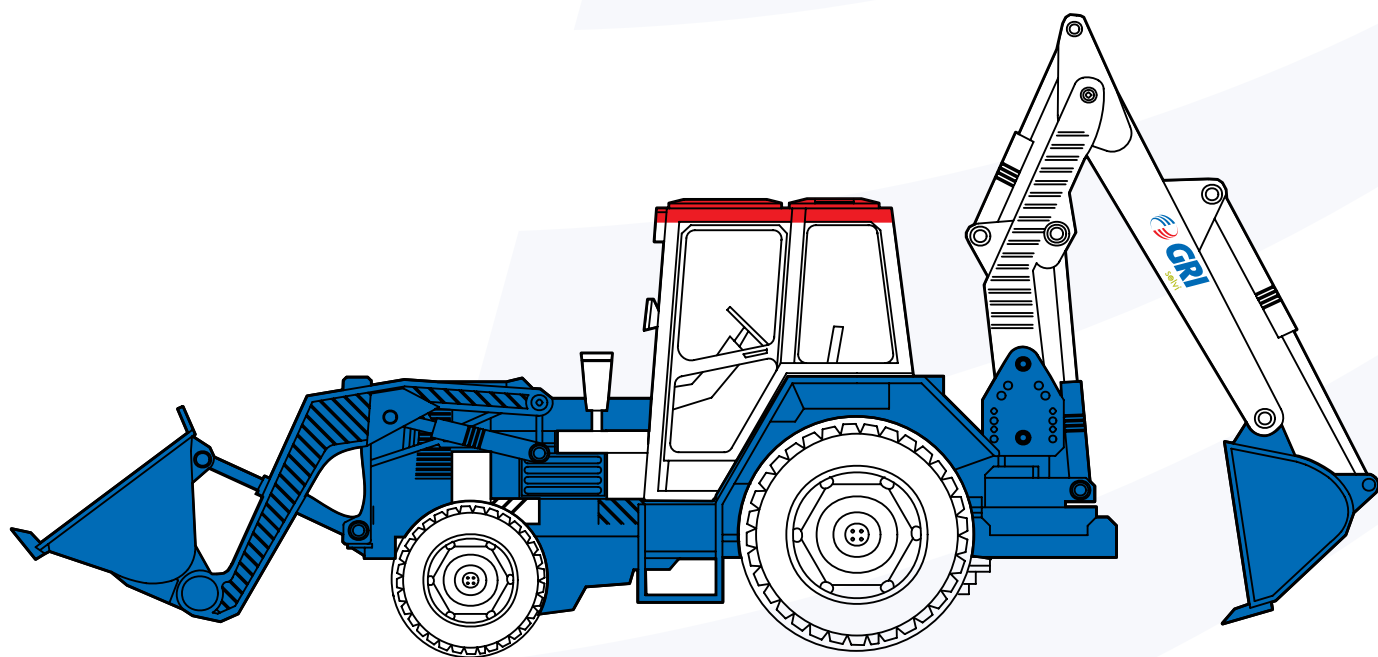
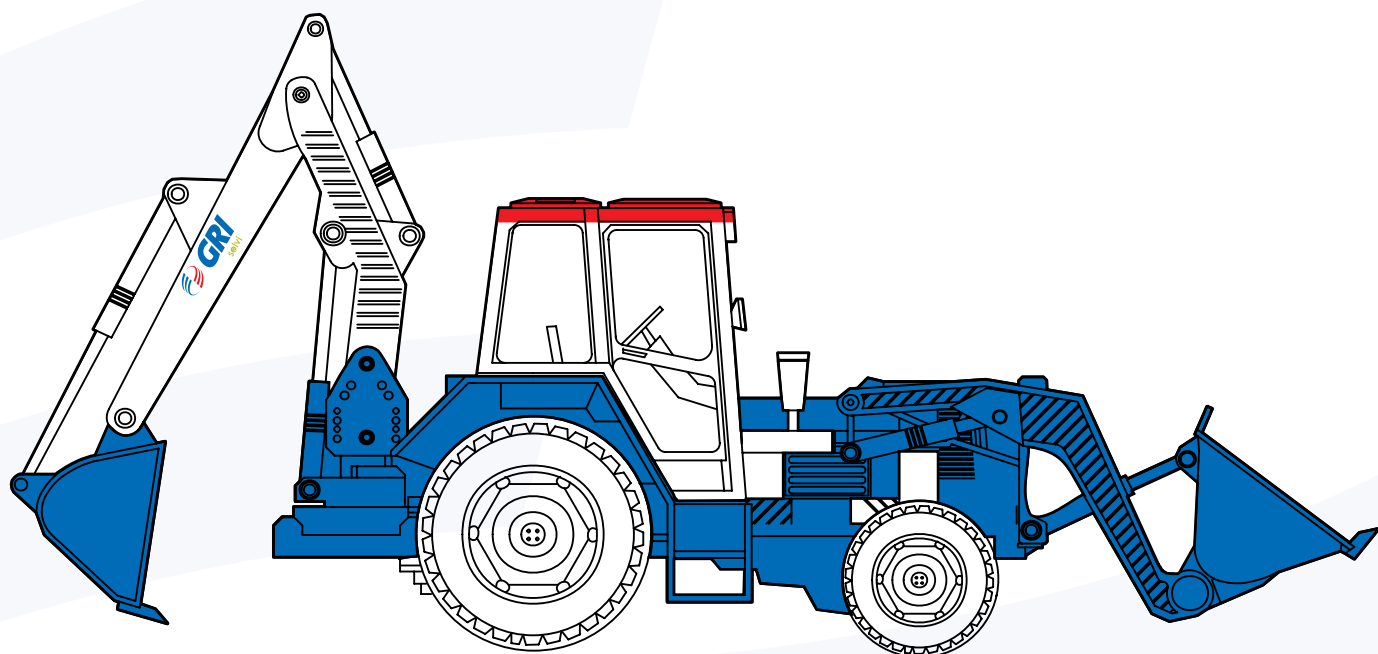



9. Veículos | Empilhadeira

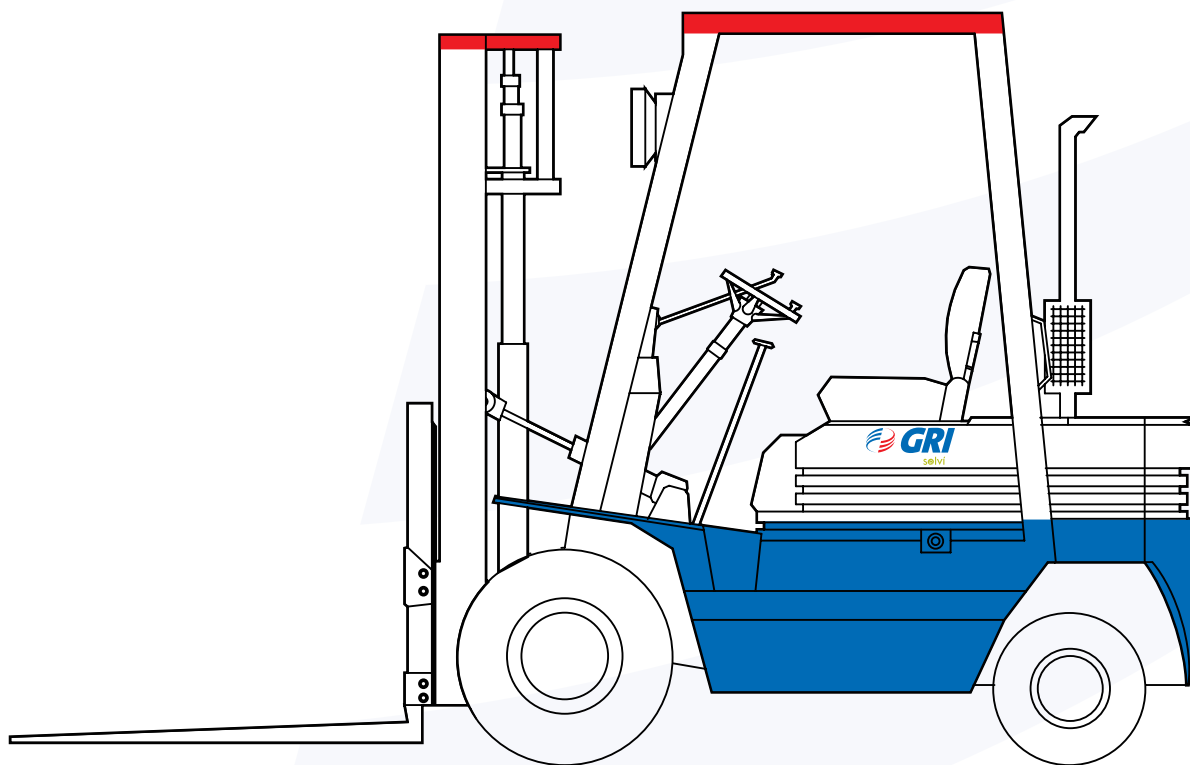
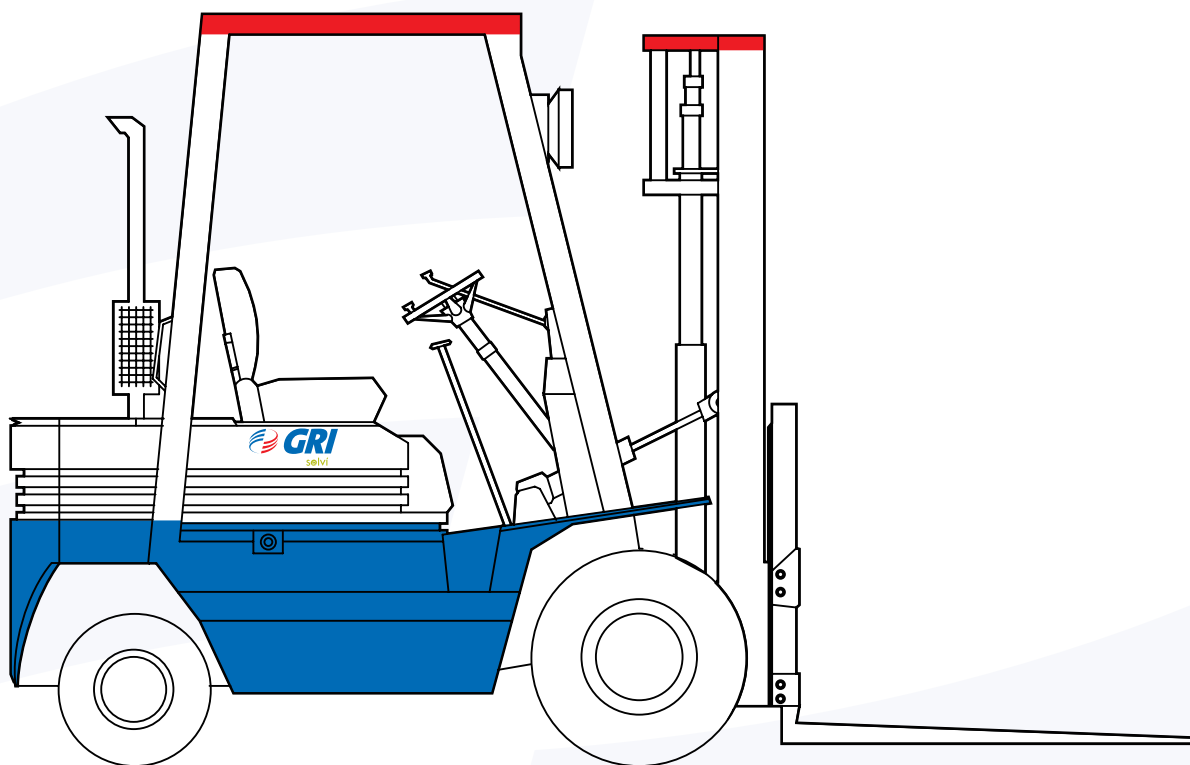



9. Veículos | Forkliftel

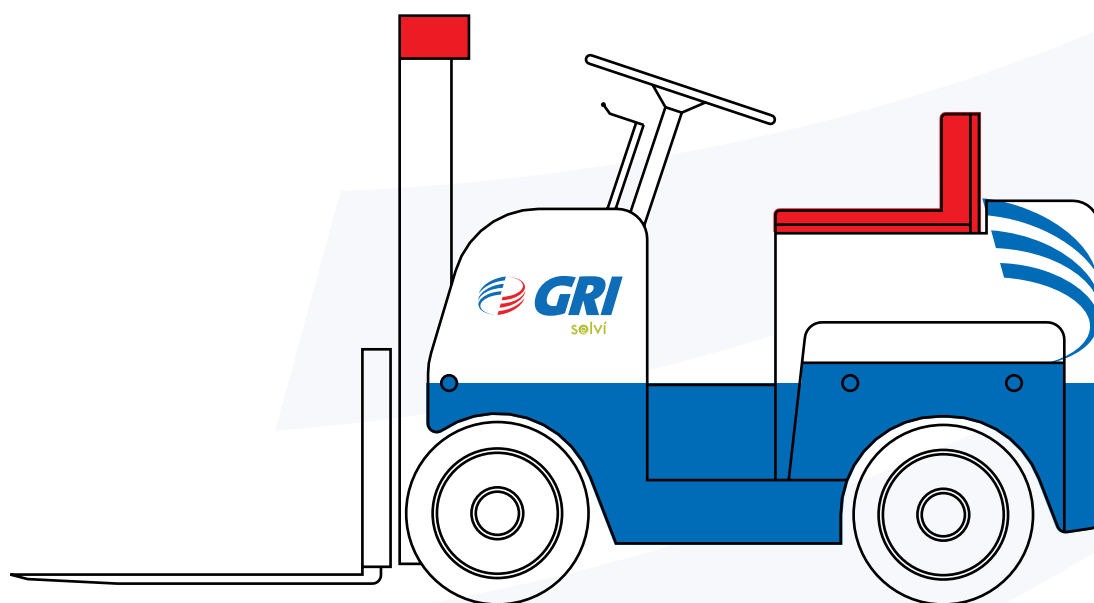
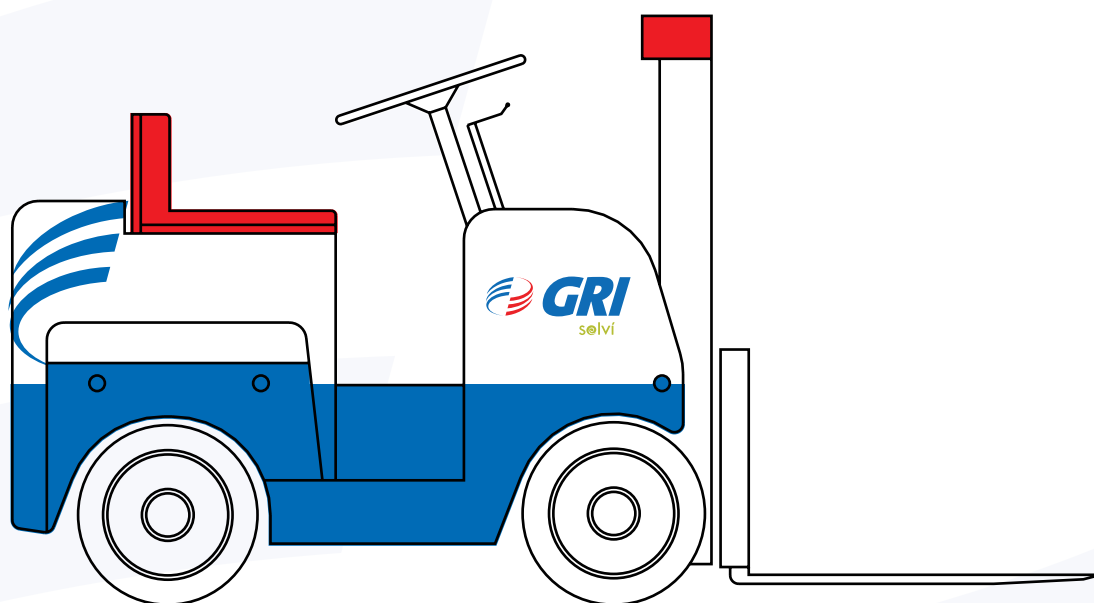



10. Tipografia

É a família tipográfica com o objetivo de uniformizar as informações escritas e unificar a identidade visual da GRI.

A tipografia institucional tem como objetivo estabelecer uma unidade visual entre o logotipo e as mídias em que serão aplicados.

A família tipográfica adotada é a Myriad, sendo também opcional a Trebuchet.



GRI Gerenciamento de Resíduos Industriais

A tipografia do logotipo em hipótese alguma poderá ser mudada ou reescrita pois a mesma é exclusiva e não disponível em arquivos de fonte true type (TTF) ou qualquer outro.

Myriad

regular	AaBbCcDdEeFfGgHhIiJjKkLlMmNnOoPpQqRrSsTtUuVvWwXxYyZz
Italic	<i>AaBbCcDdEeFfGgHhIiJjKkLlMmNnOoPpQqRrSsTtUuVvWwXxYyZz</i>
Bold	AaBbCcDdEeFfGgHhIiJjKkLlMmNnOoPpQqRrSsTtUuVvWwXxYyZz
Bold Italic	<i>AaBbCcDdEeFfGgHhIiJjKkLlMmNnOoPpQqRrSsTtUuVvWwXxYyZz</i>

Trebuchet MS

regular	AaBbCcDdEeFfGgHhIiJjKkLlMmNnOoPpQqRrSsTtUuVvWwXxYyZz
Italic	<i>AaBbCcDdEeFfGgHhIiJjKkLlMmNnOoPpQqRrSsTtUuVvWwXxYyZz</i>
Bold	AaBbCcDdEeFfGgHhIiJjKkLlMmNnOoPpQqRrSsTtUuVvWwXxYyZz
Bold Italic	<i>AaBbCcDdEeFfGgHhIiJjKkLlMmNnOoPpQqRrSsTtUuVvWwXxYyZz</i>